



St. Laurence Catholic Primary Year 2 Curriculum Letter Spring Term 2026

Class Teacher – Mrs Groves

Teaching Assistant – Mrs Ligotti

Through God's grace, a community growing
in knowledge and understanding

RE

In Religion children will be exploring the following topics:

Galilee to Jerusalem : Jesus's life and ministry

Desert to Garden: Jesus's death and resurrection

Giving Opportunities—Lent

English Writing

Children will complete the following units. At the end of these units, pupils will be able to:

Poetry on a theme

- Make connections between poems
- Prepare and perform a humorous poem

Non-chronological reports

- Maintain the present tense
- Use simple subordinating conjunctions (e.g. when, if, because)
- Write to inform

Recount from personal experience

- Write in the first person
- Write in the past tense
- Recount a real event or experience

English reading

We will be learning to infer, predict and summarise from the following key texts:

- **The Quangle Wangle's Hat**
- **Aesop's Fables**
- **The Street beneath my Feet**
- **Coming to England**
- **The Rhythm of the Rain**

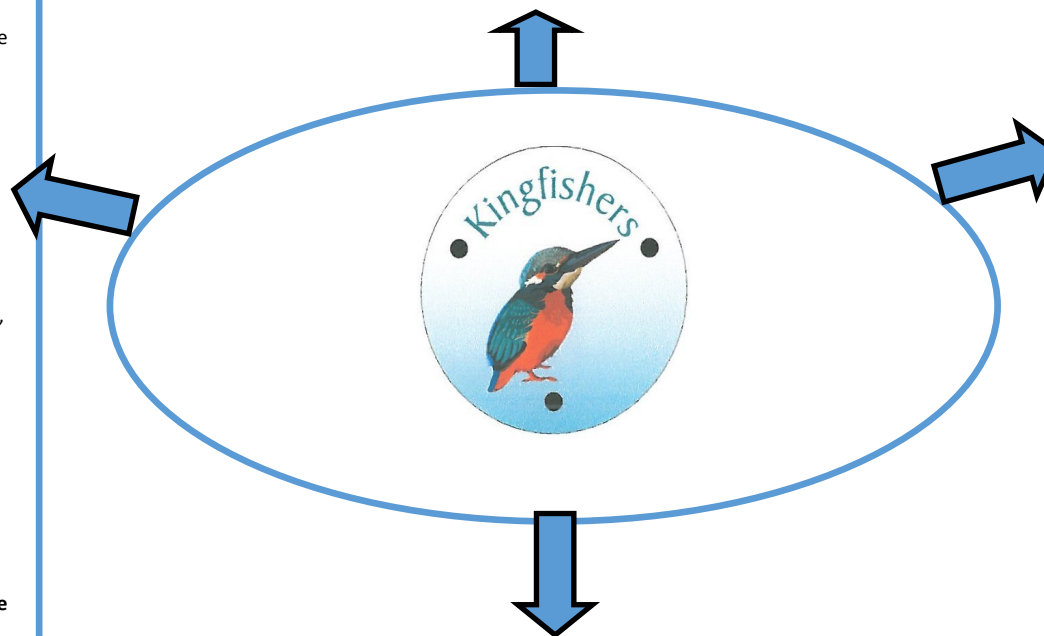

Maths

In **Year 2** children will develop their oral, mental and written skills in:

- Recognising and using money
- Multiplication and Division
- Length and Height
- Mass, capacity and temperature

Children will focus on each area of maths for an extended number of lessons allowing them to deepen their understanding.

Children also participate in a short daily mastering number session aiming to secure firm foundations in the development of good number sense for all children improving fluency in calculation and a confidence and flexibility with number.

Our School calculation policy provides further details of the maths vocabulary, resources and strategies that are accessed and taught within the Year 2 curriculum.

PE—Children will participate in weekly lessons on target games up until half term and then athletics lessons after half term.. They will also participate in Forest School activities each week.

Music— Children will work on a range of musical skills including improvisation, composition and performance through exploring a broad range of musical instruments and singing techniques developed within a range of activities.

PSHE— The children will explore the individual's relationship with others. Building on the understanding that we have been created out of love and for love, this module explores how we take this calling into our family, friendships and relationships, and teaches strategies for developing healthy relationships and keeping safe.

DT — sew your own pencil case

Spring Term 1 (until half term)

a simple circuit

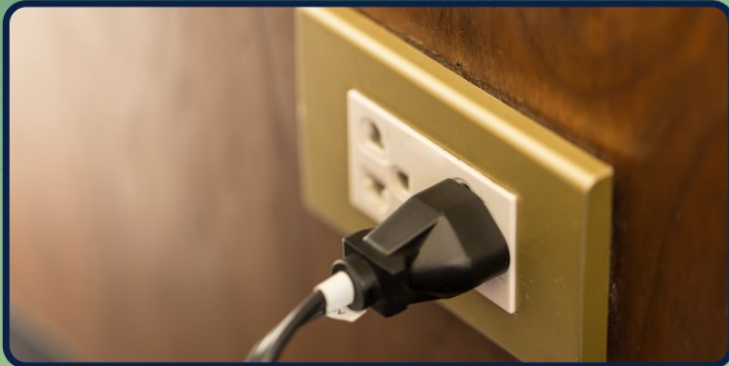
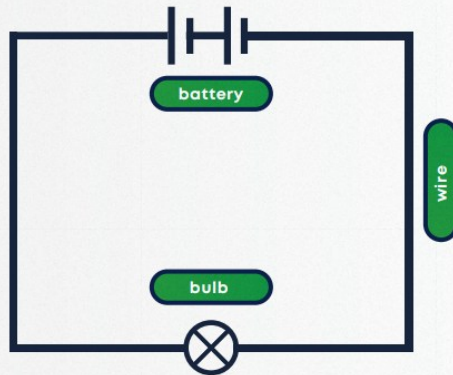

electricity can be dangerous; we must follow safety rules

KEY VOCABULARY

electricity

electricity is a **form of energy** that helps to make things work

electrical current

the **flow of electricity**

electric shock

if we allow electrical current to flow through our bodies **it can hurt us**

circuit

a **path** which electricity flows around

battery

a **store of energy**

light bulb

a piece of equipment that **converts electrical energy to light energy**

switch

a piece of equipment that can **make or break an electrical circuit**

wire

a **thin piece of metal** (usually covered in plastic) that allows electricity to flow through it

conductor

an electrical conductor **allows electricity to flow** through it

insulator

an electrical insulator **does not allow electricity to travel** through it

battery



bulb



wire

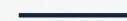

switch



electrical symbols

Spring Term 1 (until half term)



Geography

PKC



British Isles



KEY VOCABULARY

the United Kingdom

the union of the following countries: **England, Wales, Scotland and Northern Ireland**

the British Isles

the **group of islands**, located in north-western Europe, that include **Britain and Ireland and over six thousand smaller islands**

island

a piece of **land entirely surrounded by water**

loch

the Scottish name for **a large lake**

munro

the Scottish name for **a mountain**

valley

sloping land in between two mountains or hills: valleys often have a river running through them

coast

an **area where land meets sea**: along the coastline, at the edge of land, you could find stony or sandy beaches and cliffs

inhabited

a place that has **people living in it**

uninhabited

a place that has **no people living there**



Cape Town, South Africa



Cape Town



geographers sometimes compare different places (Cape Town is a city in South Africa)

Spring Term 1 (until half term)



Art

PKC



Portraits and Self-Portraits



portraits

Leonardo da Vinci



Mona Lisa (1503-06)

Hans Holbein the Younger



Edward VI as a Child (1538)

self-portraits

Vincent Van Gogh

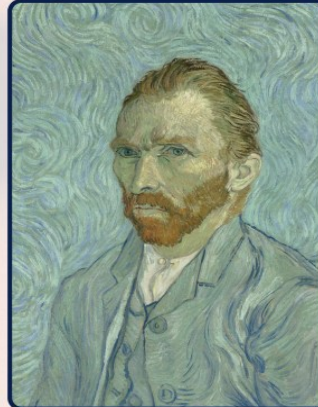

Self-portrait (1889)

Pablo Picasso

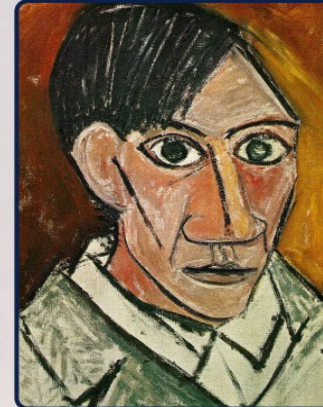

Self-portrait (1907)

Rembrandt van Rijn

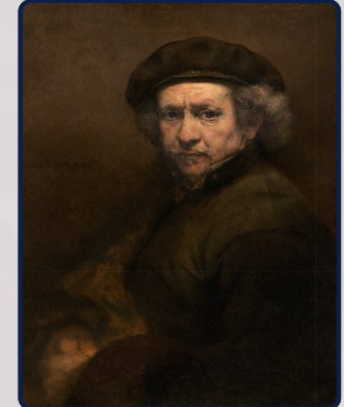

Self-portrait (1659)



KEY VOCABULARY

portrait

a piece of **artwork showing a person**

self-portrait

a **portrait that an artist creates of themselves**

facial features

eyes, nose, mouth, ears

skin tone

the **shades of a person's skin**

represent

how an artist shows **what a person is like in a portrait**

cubism

a way of painting and drawing where artists show **more than one view of something in the same picture**, like looking at many sides of a cube at once

Spring Term 2 (after half term)



plant

a **living thing that grows in one place** such as an oak tree, a sunflower or a tomato plant

root

the **part of a plant that acts as an anchor**, fixing the plant into the ground and absorbing water to help the plant to grow

stem

the part of the plant that grows above the ground that leaves and flowers grow from (the stem is also used to **transport water around the plant**)

leaves

a plant's leaves **absorb sunlight and turn it into energy** that the plant uses to grow

seed

the small part of a flowering plant that **can grow into a new plant**

seedling

a **young plant**, after a seed has germinated

bulb

a **store of a plant** that lives underground

germinate

when a seed **begins to grow into a seedling**

crops

plants grown by farmers to sell to people who will eat them

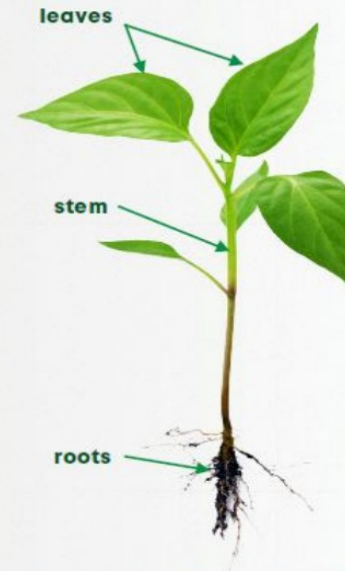

this seedling is a young plant, it will grow larger and will create its own seeds to reproduce



some plants are grown for humans and animals to eat; this farmer is harvesting crops

bulb



seeds



oak tree



oak leaf



acorn



Spring Term 2 (after half term)



History

PKC



The Tudors

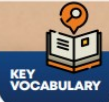

Protestant

a division of Christianity: Protestantism has simpler churches without much decoration, and **the Pope is not in charge**

Catholic

another division of Christianity: in Catholicism, the bible is in Latin, **the Pope is head of the church**, and churches are beautifully decorated with lots of gold and paintings

The English Reformation

when **England became a Protestant country** and King Henry VIII became head of the Church of England

Dissolution of the Monasteries

King Henry VIII closed the monasteries and abbeys (religious places) of England and took their land and wealth

heir

the person who **has a right to be king/queen** after the king or queen dies

execute

to **kill**

peasant

a **poor person**

Henry VIII and his children

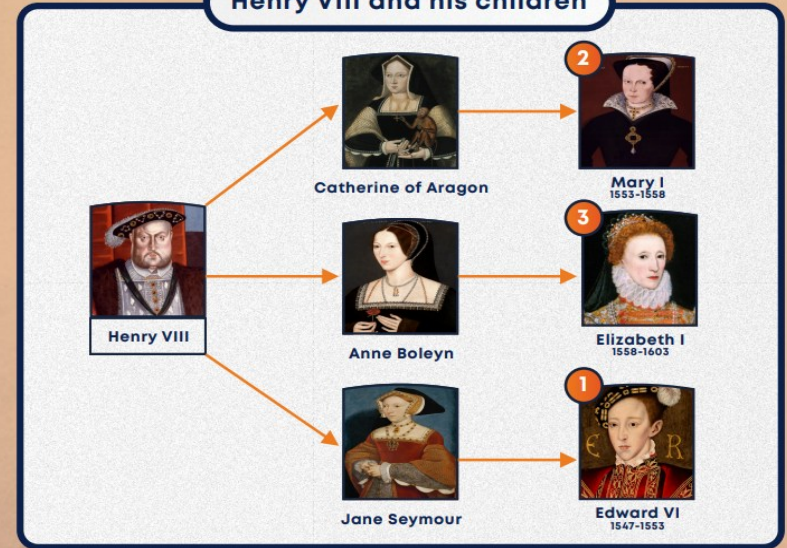

the wives of Henry VIII



Spring Term 2 (after half term)



Landscape and Symmetry

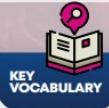

KEY VOCABULARY

landscape

a **painting or drawing of a large area of the natural world**, e.g., mountains or fields

seascape

a type of landscape painting which is of **the sea**

method

a **way of doing something**, e.g., the steps for painting a picture

sketch

a **rough drawing or painting**, possibly to be looked at to be able to complete a finished drawing or painting

brushstroke

the **mark made by a paintbrush**

symmetry/
symmetrical

where the parts of a picture or object **look exactly the same on both sides**, a mirror image

natural
materials

things from nature, used to make art, e.g., leaves, sticks or stones

temporary

something which **lasts for a short time**

The Last Supper
(1495-1498)

Leonardo da Vinci



Turner



Snowstorm (1842)

Constable



Salisbury Cathedral from the Meadows (1831)

Core Reading texts



This book tells the true story of Floella Benjamin's childhood journey to Britain from the Caribbean (a Windrush Generation girl). It starts with descriptions of her life in Trinidad and how her family, a group at a time, set sail to start a new life in London. On arriving in England, Floella encountered a less than friendly welcome but was determined to persevere and create a better life. This book follows Floella's journey as she experiences moving countries, making new friends and working hard to achieve success. This is an inspiring and optimistic book which shows how determination and courage can help you overcome any challenges.

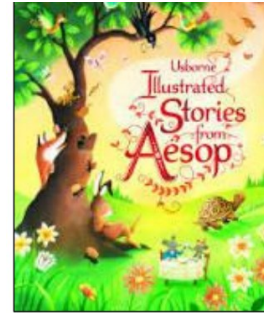

This is an anthology of the retelling of thirty of Aesop's fables. The stories are all accompanied with illustrations. The fables are organised around the themes of pride, greed, friendship, retorts, comeuppance, cunning, trickery and quarrels. Each of the fables conveys a moral with a message about how to behave towards others. *The Sun and the Wind* focuses on the lesson that often gentle persuasion is more effective than the strongest force.

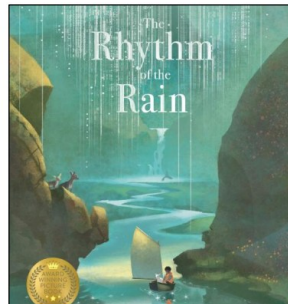

This book tells the story of the water cycle in a very poetic way and is accompanied by stunning illustrations. It begins with Isaac emptying a jar of water into a mountain pool. The reader is then taken on the water's journey across the planet, from rivers, to seas, to oceans and to the clouds, all the while interacting with humans, animals and the natural world. Finally, the water returns to its starting point. The story puts meaning into how water is used and explores the global life cycle of water and weather. It also serves as a reminder that our actions and experiences are an important part of the bigger picture.

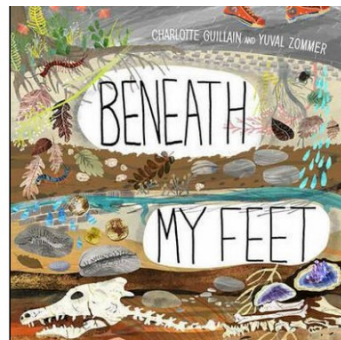

This book takes the reader on an exploratory underground journey to the centre of the Earth and back again passing through both a rural and an urban setting. It is an expanding concertina book which is jam-packed with facts about Earth. The vibrant illustrations are continuous and run seamlessly from one page into the next, allowing the reader to trace the journey without any page turning.



This whimsical nonsense poem was written by Edward Lear, a Victorian author, poet and artist. The poem tells the story of a lonely creature called the Quangle Wangle that lives on the top of a Crumpetty Tree and wears a very large hat. His loneliness comes to an end when a variety of creatures (both real and made up) with daft names and qualities come to build their houses on his hat. The text is delightfully silly, mixing real and nonsense words effortlessly. It is particularly fun when read out loud.

Baptism



The

candidate has water poured over their head three times. I baptise you in the name of the Father, and of the Son, and of the Holy Spirit.

John the Baptist

John's mother is Elizabeth, who is Mary's cousin. John baptised Jesus in the River Jordan.



This is when Jesus realised his full mission. He is a prophet.

Miracle

A sign or wonder such as healing or controlling nature that can only happen because of God's power.

sorrow

A deep feeling of loss, sadness or disappointment.

parable

A story that Jesus used to teach people a moral or spiritual lesson.



Temptation

If you want to do something that is forbidden, this is a temptation. To resist a temptation, this is a great accomplishment and makes heaven rejoice.

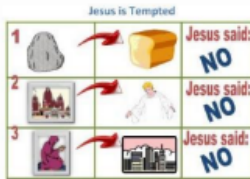

Sin

Sin is something bad you do even though you know you shouldn't do it. Sin is also if you do not do something good although you know that you should do it.

Forgiveness

It frees you from the evil you or others have done.

Reconciliation

When we go to confession, we tell God we are sorry for the sins we have

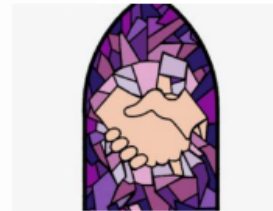

committed. God forgives us and we can have a new beginning with God.

